

TOSHIBA

Toshiba Air Conditioning Sales & Services (A division of Carrier Singapore (Pte) Limited)

1 Venture Ave, #08-02 Perennial Business City, Singapore 608521

Call: 6567 5337 | Website: www.Toshiba-Aircon.com.sg | E-mail: enquiries.toshibaircon@carrier.com

All features and specifications are subject to change without prior notice.

A Carrier Company.

T2026-MAR-SPI EDGE R32-SG

@2026 Carrier. All Rights Reserved.

TOSHIBA

SPI Edge

Engineered for precision,
built for better comfort.
Push the Edge of Performance.



COMMITTED TO **PEOPLE** COMMITTED TO THE **FUTURE**

Carrier is a global leader in intelligent climate and energy solutions, with a diverse and world-class workforce (~53,000 employees, 6,000+ engineers). The company has a long and heralded history filled with innovations, starting with Willis Carrier's invention of modern air conditioning on July 17, 1902. In April 1999, Toshiba Carrier Corporation (TCC) was founded as a joint venture between Carrier and Toshiba Corporation, with the focus on a global provider of residential and light-commercial HVAC solutions including VRF and heat pump products; Toyo Carrier Kogyo became a part of TCC.

CJC introduced many innovative technologies in the HVAC industry to name a few as follows:

- In 1961, the world's-pioneering split type of air conditioning for residential applications was launched. The air conditioning separated the compressor which makes large vibration and noise to the outdoor.
- In 1980 and 1981, the world's first inverter air conditioners for commercial and residential applications were developed and commercialized, respectively. In March 2021, these achievements on the world's first inverter air conditioning were recognized by the Institute of Electrical and Electronics Engineers (IEEE) as an IEEE Milestone for the historic significance of the achievement in electrical and electronics fields.

- In 1998, the division pioneered the use of R410A refrigerant (ODP=0) as an alternative refrigerant of R22, which was dominantly used in the market.

- With its focus shifted from Japan domestic to overseas markets and from residential to commercial segment, TCC strived to evolve its technologies in compressors and inverters and applied such technologies to variable refrigerant flow (VRF) systems and modular chillers.

- In **August 2022**, upon completion of Carrier's acquisition of Toshiba Corp's stake in TCC and became a part of Carrier. In May 2024, TCC was renamed Carrier Japan Corporation (CJC)

AWARDS AND RECOGNITIONS:

The Energy Conservation Grand Prize, sponsored by the Energy Conservation Center, Japan, since 1990, is one of the most prestigious honors in Japan for HVAC manufacturers. CJC received 32 honors at the award, including eight times of the highest honor. Recent Award-Winners and Best Sellers at CJC:

2018: FLEXAIR, a ductless spot zone air conditioning system.

2020: Super Multi u series, Toshiba-branded global VRF series, using "triple rotary compressors" for its outdoor units.





DISCOVER SUPERIOR EFFICIENCY WITH **SPI Edge**

Upgrade your experience with SPI Edge, a system that delivers remarkable energy savings thanks to its cutting-edge technology. Designed for superior performance and cost-effectiveness, SPI Edge is your smart choice when looking to maximize results while lowering expenses.



TOP CLASS COP 4.80*

Thanks to Toshiba's unique energy saving technologies, SPI Edge achieves higher energy efficiency to deliver optimal performance.

ENERGY SAVING

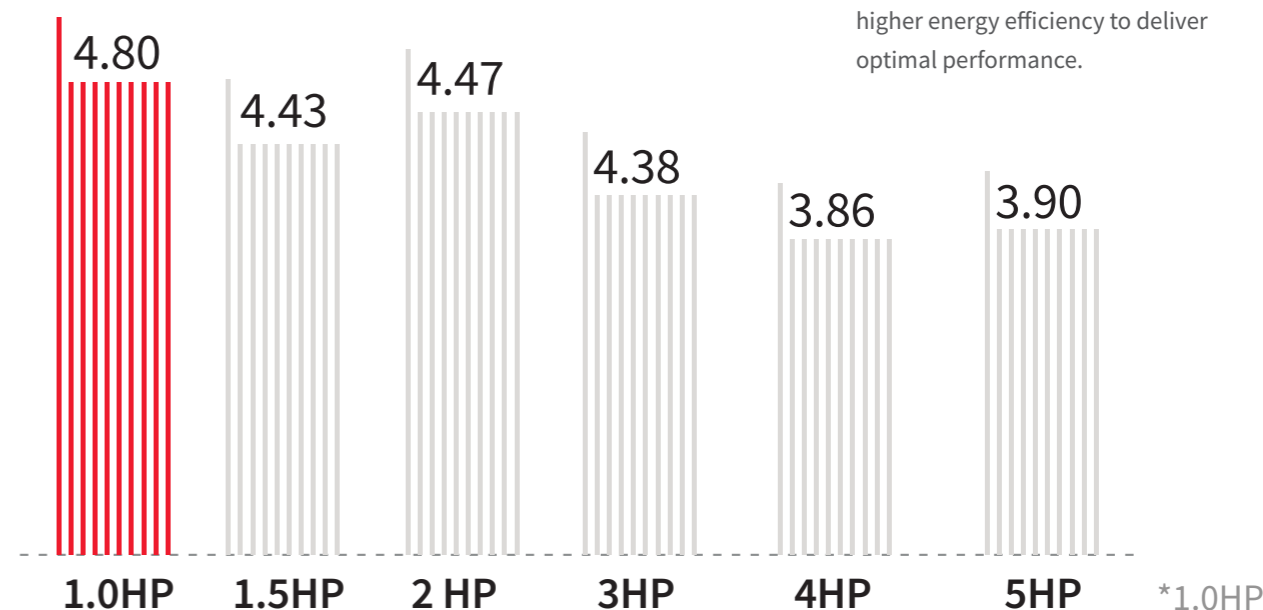

SPI Edge is engineered for optimal efficiency and has attained a top-rated energy label, reflecting its outstanding performance and commitment to sustainability. Selecting SPI Edge ensures superior energy savings, reliable operation, and a forward-looking investment, ideal for individuals seeking excellence without compromise.



HP	OUTDOOR UNIT MODEL	INDOOR UNIT MODEL			
		HIGH WALL	4 WAY CASSETTE	CEILING	STANDARD DUCT
	H630 x W800 x D300 mm				
1.0HP	RAV-GE1002AP-SG	RAV-GE1002KRP			
1.5HP	RAV-GE1302AP-SG	RAV-GE1302KRP			
	H890 x W900 x D320 mm				
2.0HP	RAV-GE1802AP-SG	RAV-GE1802KRP	RAV-GE1802UP	RAV-GE1802CP	RAV-GE1802BP
3.0HP	RAV-GE2502AP-SG	RAV-GE2502KRP	RAV-GE2502UP	RAV-GE2502CP	RAV-GE2502BP
4.0HP	RAV-GE3602AP-SG	RAV-GE3602KRP	RAV-GE3602UP	RAV-GE3602CP	RAV-GE3602BP
5.0HP	RAV-GE4202AP-SG		RAV-GE4202UP	RAV-GE4202CP	RAV-GE4202BP

COMPACT & LIGHT-WEIGHT

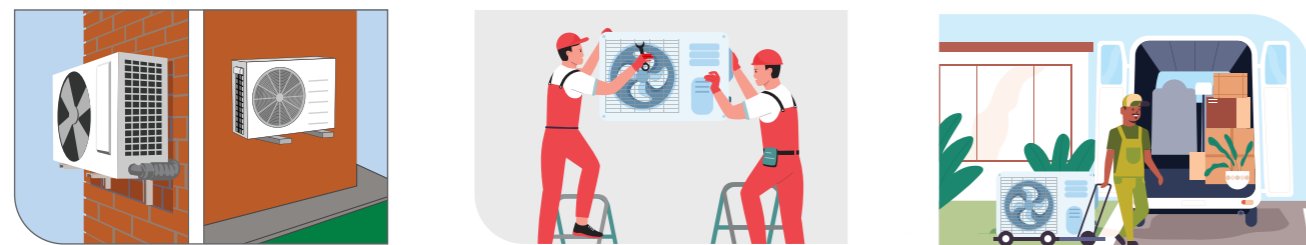

- Easy to install outdoor unit on the wall by rack or an angle.
- Easy to carry and transportation.



H630 x W800 x D300 mm
1.0HP 27kg, 1.5HP 30kg

H890 x W900 x D320 mm
2.0HP & 3.0HP 51kg, 4.0HP & 5.0HP 59kg

SELF-CLEAN OPERATION WITH AQUA-RESIN COATED COIL



The mechanism of the wash-off by aqua-resin coated heat exchanger fins of indoor units.

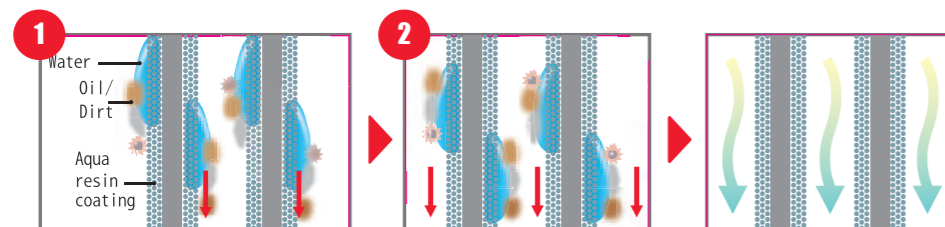
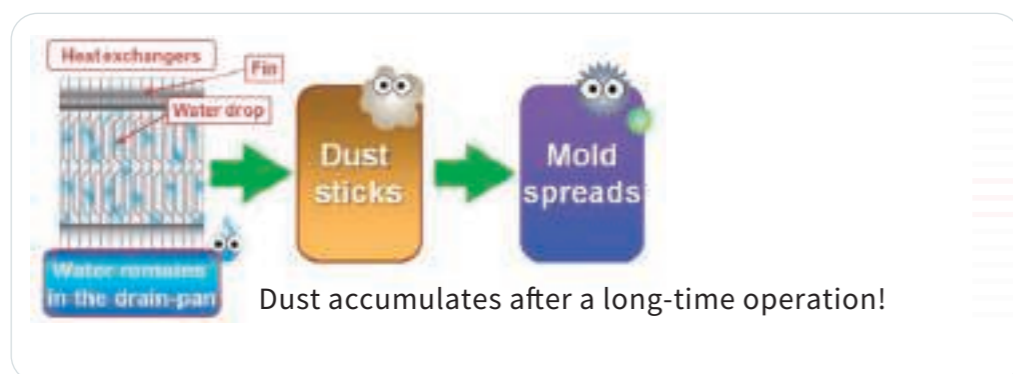

- The "Aqua-resin" prevents dirt and oil from sticking on the fins.
- The dew condensation water flush out dirt and oil.
- A drying operation inhibits the propagation of mold after washing.

WIDE OPERATING RANGE

SPI Edge provides an extensive operating temperature range designed to accommodate user needs for consistent comfort throughout the year.



AUTO-RESTART FUNCTION

For stable operation in area with unstable electricity, SPI Edge has AUTO restart function as standard for blackout.

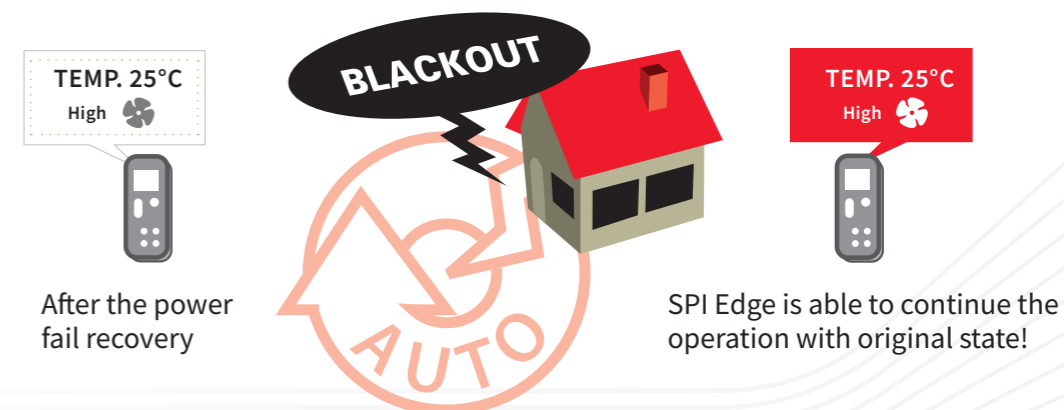

AIR-FLOW CONTROL

Indoor units can provide 5-step fine control of air volume, the wind strength can be controlled with higher accuracy.

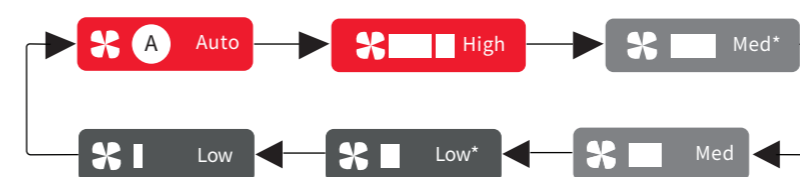

*The function is available with wireless remote controller and specific wired remote controller only.



ENDURING DURABILITY FOR HIGH PERFORMANCE

ALUMINUM ALLOY HEAT EXCHANGER

Toshiba's specially designed aluminum alloy heat exchanger enhances the SPI Edge's corrosion resistance and durability. Adopting a special alloy that forms the tubes, SPI Edge is able to lower its corrosion rates and extend product life.



ANTI-CORROSION

With a new corrosion resistant aluminum alloy, the heat exchanger becomes highly durable. A salt spray test has been conducted to demonstrate the corrosion-resistant capability of our products in corrosive environments for a certain period of time.

Testing standard: JIS Z2371

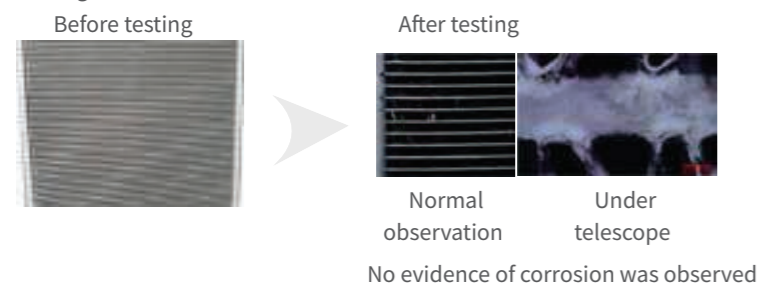

After thorough testing, the heat exchanger maintained its structural integrity without exhibiting signs of corrosion, clearly demonstrating its durability even in highly corrosive conditions.

FIN GUARD INSTALLED

The fin guard is installed to strengthen safety, protecting installers and users from direct contact with heat exchanger fins and potential injury.

PLASTIC JOINT COVER AND RUBBER SHEET INSTALLED

Plastic joint covers and rubber sheets isolate aluminum heat exchangers from steel components to effectively reduce and ensure long-term durability.

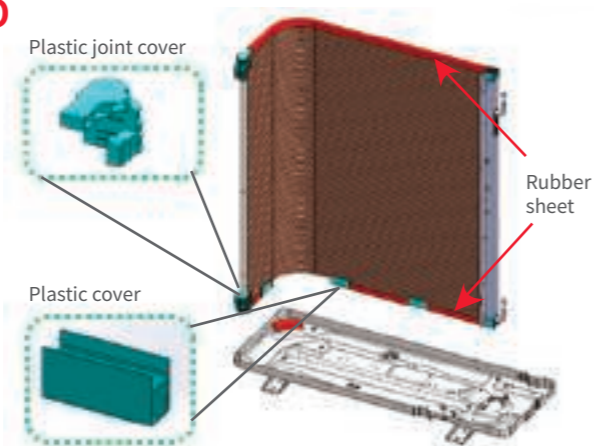

TWIN ROTARY COMPRESSOR

Enhanced compressor reliability with our new advanced oil-recovery control system – designed to prevent oil shortages and ensure consistent operation. Built on proven expertise, it achieves high performance and uncompromising quality in demanding environments.



SEALED-UP INVERTER BOX

The SPI Edge inverter box is fully sealed to prevent malfunctions from sand, dust, and small animals, enhancing the operation stability of the unit.

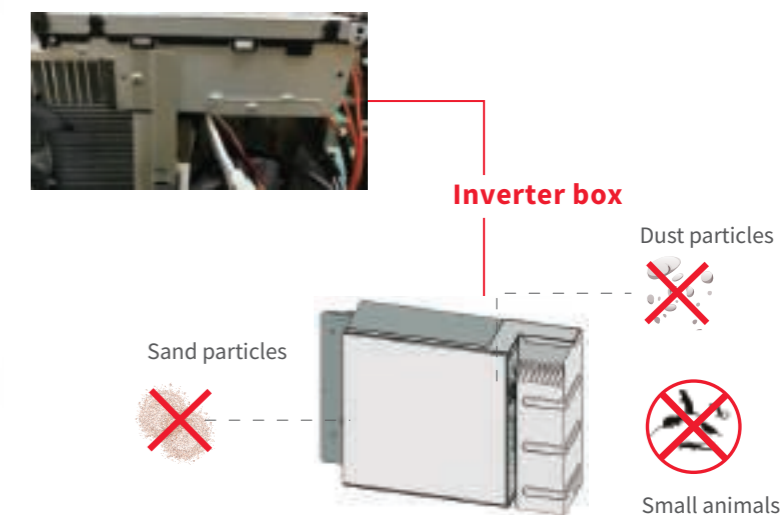

INTEGRATED STRAINER IN GAS PIPE

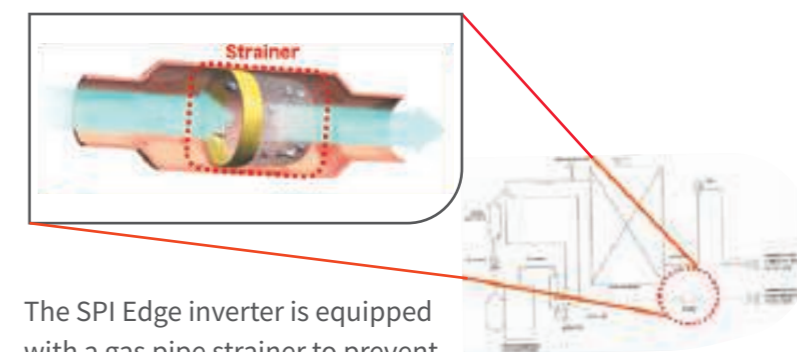

The SPI Edge inverter is equipped with a gas pipe strainer to prevent dust and metal particles from entering key components, ensuring stable performance and long-term reliability.

CONNECTIVITY AND SMART CONTROL

Experience unparalleled convenience and effortless control with Toshiba SPI Edge System. Adjust your ideal climate to customize your lifestyle anytime, anywhere via Toshiba Home AC Control App.

Toshiba Home AC Control App

Effortlessly control your indoor comfort, energy use, and multiple units—all in one smart app

- Seamless Multi-user Access: Share control with up to 5 users.
- Superior Climate Mastery: Customize your indoor comfort with powerful, flexible climate settings.
- Ultimate Group Management: Convenient command for up to 3 groups with a total of 16 units.
- Smart Energy Insights: Optimize your savings by tracking energy consumption with the advanced Energy Monitor Function.

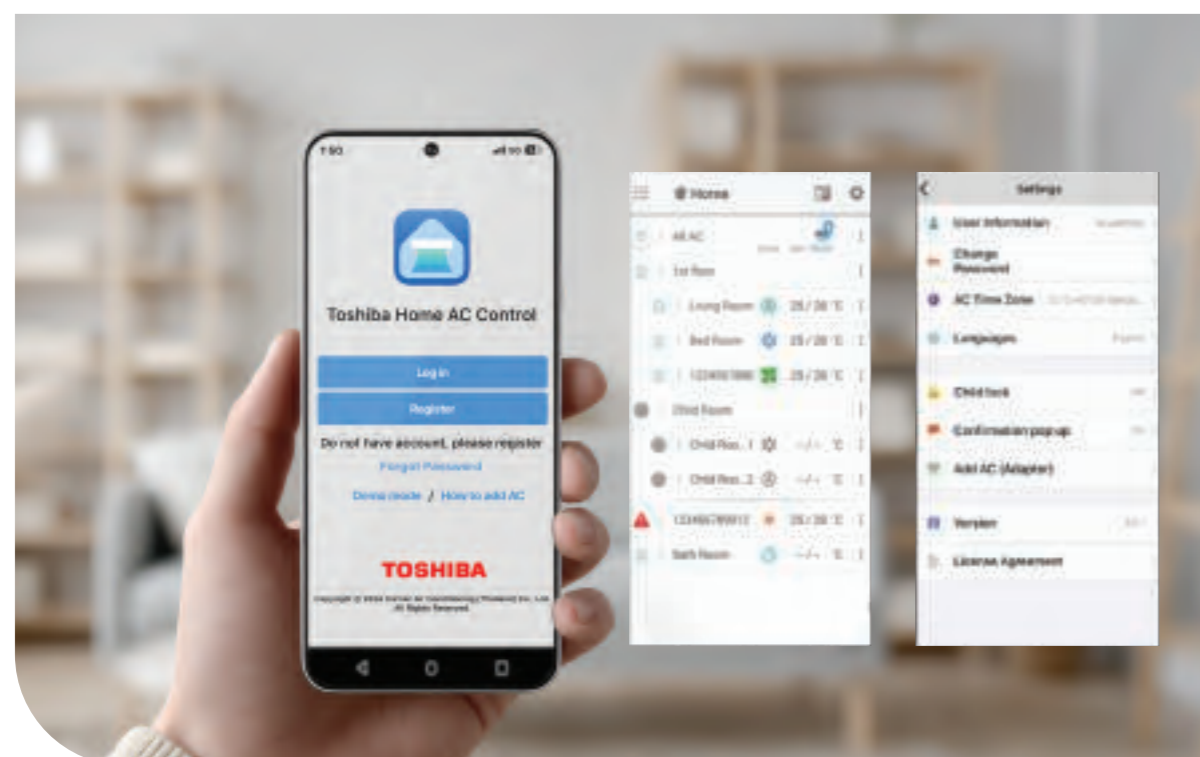
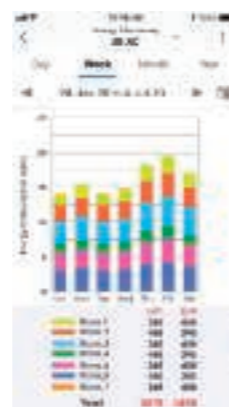

Effortlessly personalize your climate and achieve superior comfort in seconds—all with one intuitive touch.

Color-intuitive mode switching

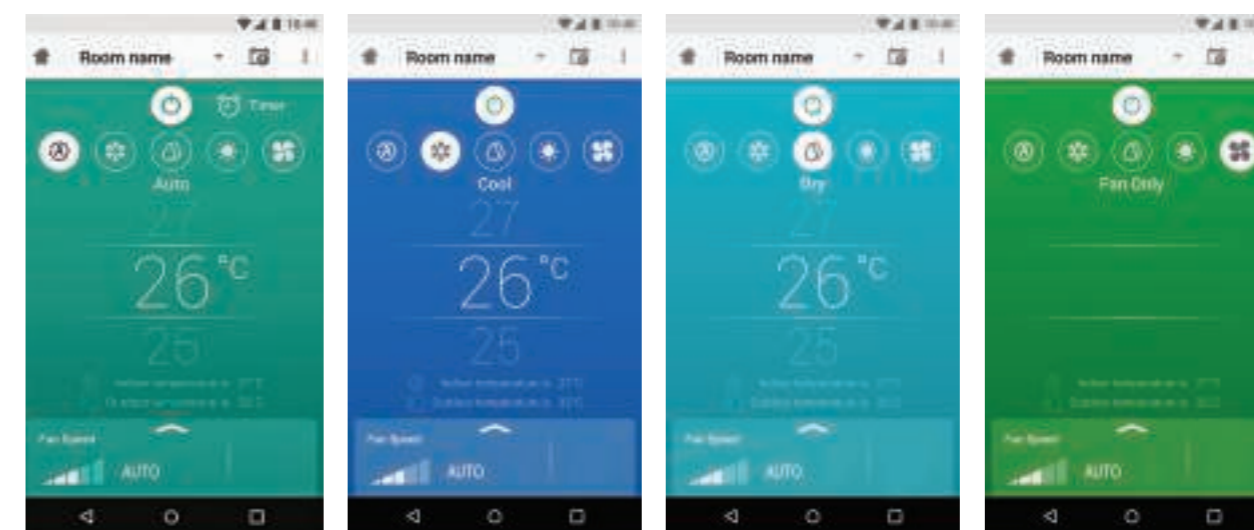

Comprehensive Customization

- ON/OFF
- Operation Mode
- Fan Speed
- Power Selection
- Weekly Schedule
- Holiday Timer
- Group Management
- Key Lock
- Indoor & Outdoor Temperature Display





4-WAY CASSETTE TYPE RAV-GE**02UP

Comfort

- 2 louver shape options are available—straight flow louver and wide flow louver, ensuring optimal air distribution.
- Individual setting of louver position with 3 different swing modes: Standard, Diagonally opposite and Turn-around.

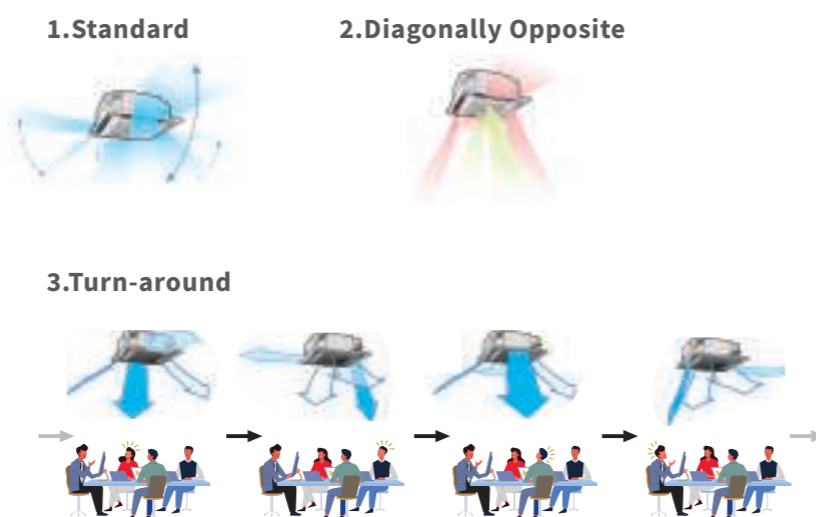

Easy Installation

- Compact chassis with a height of *256mm only.*
- Lightweight unit for easy and quick installation.
- Simplified panel installation using pre-installed bolts on the unit.

*For selective models.

Reliability

Built-in high-lift drain pump.

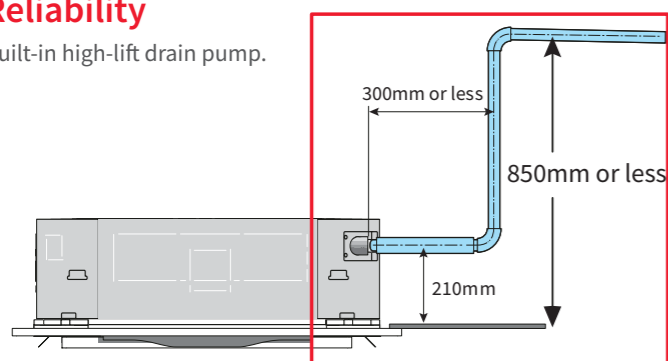

Wide flow louver panels

Maintains a consistent appearance when multiple units are installed.



RBC-U31PGXP(W)-SG1

Technical Specification

Equivalent		HP	2.0	3.0	4.0	5.0	
Model Name	Indoor unit		RAV-GE1802UP	RAV-GE2502UP	RAV-GE3602UP	RAV-GE4202UP	
	Outdoor unit		RAV-GE1802AP-SG	RAV-GE2502AP-SG	RAV-GE3602AP-SG	RAV-GE4202AP-SG	
Power supply (Outdoor unit)			1-phase 50Hz 220-240V				
Cooling capacity (Min-Rated-Max)		kW	1.2-5.3-5.6	2.0-6.3-8.5	4.0-9.0-11.2	4.0-11.0-13.2	
Power consumption (Rated)		kW	1.14	1.41	2.09	2.82	
Coefficient of Performance (COP)			4.65	4.47	4.29	3.90	
Running Current		A	6.20	6.60	9.70	12.95	
Recommended Isolator		A	16	20	32	32	
Indoor unit	Airflow (H/M/L)		m ³ /h	1050 / 870 / 780	1230 / 960 / 810	2010 / 1440 / 1170	2130 / 1440 / 1230
	Sound pressure (H/M/L)		dB(A)	35 / 31 / 27	35 / 31 / 28	46 / 42 / 37	47 / 43 / 39
	Panel model			RBC-U31PGXP(W)-SG1			
	Dimension (HxWxD)	Main unit	mm	256x840x840	256x840x840	319x840x840	319x840x840
		Panel	mm	30x950x950	30x950x950	30x950x950	30x950x950
Weight	Main unit	kg	20	20	24	24	
	Panel	kg	4	4	4	4	
Outdoor unit	Compressor	Type		Twin Rotary	Twin Rotary	Twin Rotary	Twin Rotary
		Motor output	W	1050	1050	1500	3750
	Refrigerant charge(R32)	kg	0.87	1.00	1.35	1.40	
	Sound pressure	dB(A)	57	57	59	60	
	Dimension (HxWxD)	mm	890x900x320	890x900x320	890x900x320	890x900x320	
Piping connections	Weight	kg	51	51	59	59	
	Liquid side	mm	6.4	9.5	9.5	9.5	
	Gas side	mm	12.7	15.9	15.9	15.9	
Maximum total piping length		m	50	50	50	50	
Maximum height difference		m	30	30	30	30	
Operation range		°C	15 ~ 46	15 ~ 46	15 ~ 46	15 ~ 46	

Note: The cooling capacity is measured under the conditions specified by JIS B 8615 based on the reference piping. Indoor 27 degC Dry Bulb /19 degC Wet Bulb , Outdoor 35 degC Dry Bulb. The sound level is measured in an anechoic chamber in accordance with JIS B 8616

Accessory

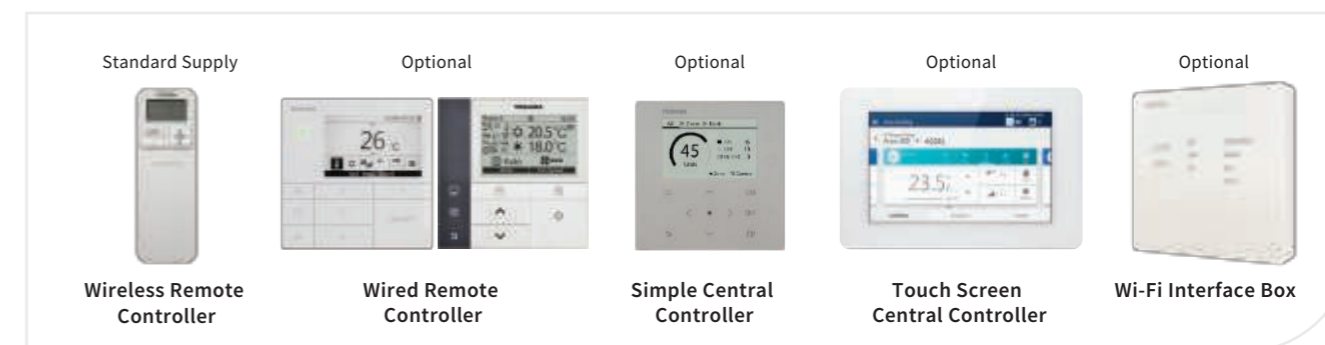



CEILING TYPE
RAV-GE02CP**

Comfort

Automatic louver control ensures consistent comfort and efficiency throughout the year. The large-diameter fan and high air volume contribute to maintaining low noise levels.

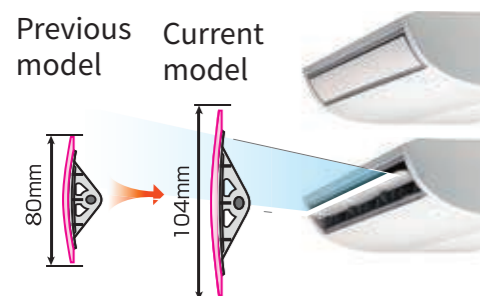

Adaptability

Optional drain pump is available





Reliability

Self-cleaning function ensures consistent, fresh airflow and minimizes the need for maintenance visits.

Easy installation and maintenance

This design offers an optimal solution for environments with limited space or where there is no available ceiling void.

Technical Specification

Equivalent		HP	2.0	3.0	4.0	5.0
Model Name	Indoor unit		RAV-GE1802CP	RAV-GE2502CP	RAV-GE3602CP	RAV-GE4202CP
	Outdoor unit		RAV-GE1802AP-SG	RAV-GE2502AP-SG	RAV-GE3602AP-SG	RAV-GE4202AP-SG
						
Power supply (Outdoor unit)			1-phase 50Hz 220-240V			
Cooling capacity (Min-Rated-Max)		kW	1.2-5.0-5.6	2.0-7.4-8.5	4.0-9.5-11.2	4.0-9.8-13.2
Power consumption (Rated)		kW	1.12	1.66	2.39	2.37
Coefficient of Performance (COP)			4.47	4.46	3.98	4.13
Running Current		A	6.00	7.80	11.05	11.00
Recommended Isolator		A	16	20	32	32
Indoor unit	Airflow (H/M/L)	m³/h	900 / 720 / 540	1750 / 1520 / 1180	2500 / 1530 / 1200	2500 / 1560 / 1220
	Sound pressure (H/M/L)	dB(A)	37 / 35 / 32	42 / 35 / 31	49 / 38 / 33	49 / 41 / 35
	Dimension (HxWxD)	mm	235x952x690	235x1269x690	235x1586x690	235x1586x690
	Weight	kg	23	29	37	37
Outdoor unit	Compressor	Type	Twin Rotary	Twin Rotary	Twin Rotary	Twin Rotary
		Motor output	W	1050	1050	1500
	Refrigerant charge(R32)	kg	0.87	1.00	1.35	1.40
	Sound pressure	dB(A)	57	57	59	60
	Dimension (HxWxD)	mm	890x900x320	890x900x320	890x900x320	890x900x320
Piping connections	Weight	kg	51	51	59	59
	Liquid side	mm	6.4	9.5	9.5	9.5
	Gas side	mm	12.7	15.9	15.9	15.9
Maximum total piping length		m	50	50	50	50
Maximum height difference		m	30	30	30	30
Operation range		°C	15 ~ 46	15 ~ 46	15 ~ 46	15 ~ 46

Note: The cooling capacity is measured under the conditions specified by JIS B 8615 based on the reference piping. Indoor 27 degC Dry Bulb /19 degC Wet Bulb , Outdoor 35 degC Dry Bulb. The sound level is measured in an anechoic chamber in accordance with JIS B 8616

Accessory

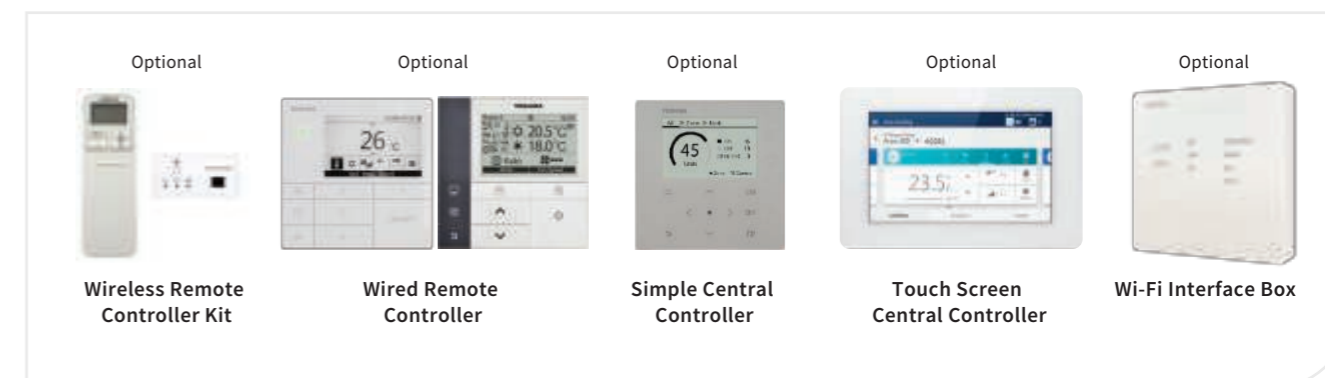



STANDARD DUCT TYPE RAV-GE**02BP

Adaptability

- Flexible design with 2 options for air intake - under air intake and rear air intake, matching your comfort and efficiency preferences.
- Designated pre-punched knockout hole allows for fresh air intake supply.
- Compact and thin chassis with a height of 275mm.

Flexible duct is accessible, ensuring comprehensive design versatility

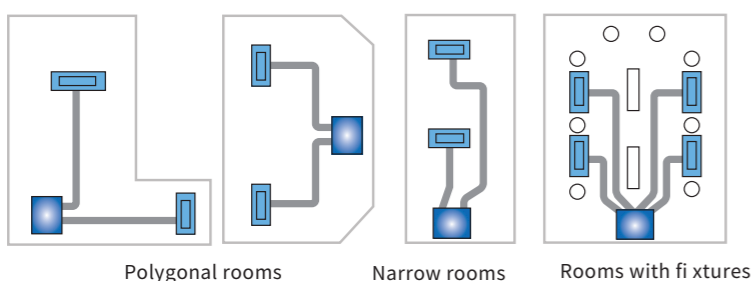

Easy to install

- Built-in high-lift drain pump.
- PC board panel easily accessible from the side of the unit.
- Optional air discharge spigot.



Technical Specification

Equivalent		HP	2.0	3.0	4.0	5.0	
Model Name	Indoor unit		RAV-GE1802BP	RAV-GE2502BP	RAV-GE3602BP	RAV-GE4202BP	
	Outdoor unit		RAV-GE1802AP-SG	RAV-GE2502AP-SG	RAV-GE3602AP-SG	RAV-GE4202AP-SG	
Power supply (Outdoor unit)			1-phase 50Hz 220-240V				
Cooling capacity (Min-Rated-Max)	kW		1.2-5.3-5.6	2.0-7.4-8.5	4.0-10.6-11.2	4.0-12.5-13.2	
Power consumption (Rated)	kW		1.32	1.96	3.40	3.62	
Coefficient of Performance (COP)			4.02	3.78	3.12	3.45	
Running Current	A		7.15	9.10	15.55	16.50	
Recommended Isolator	A		16	20	32	32	
Indoor unit	Airflow (H/M//L)	m ³ /h	900 / 710 / 540	1440 / 1110 / 960	1440 / 1180 / 960	2100 / 1650 / 1260	
	External static	Factory setting	Pa	30	30	30	50
		Pressure	Upper-Lower	Pa	120-30	120-30	120-30
	Sound pressure (H/M/L)	dB(A)		35 / 33 / 28	41 / 38 / 34	43 / 41 / 38	44 / 42 / 39
	Dimension (HxWxD)	mm		275x700x750	275x1000x750	275x1000x750	275x1400x750
	Weight	kg		23	31	31	40
Outdoor unit	Compressor	Type		Twin Rotary	Twin Rotary	Twin Rotary	Twin Rotary
		Motor output	W	1050	1050	1500	3750
	Refrigerant charge(R32)	kg		0.87	1.00	1.35	1.40
	Sound pressure	dB(A)		57	57	59	59
	Dimension (HxWxD)	mm		890x900x320	890x900x320	890x900x320	890x900x320
Piping connections	Liquid side	mm		6.4	9.5	9.5	9.5
	Gas side	mm		12.7	15.9	15.9	15.9
Maximum total piping length		m		50	50	50	50
Maximum height difference		m		30	30	30	30
Operation range		°C		15 ~ 46	15 ~ 46	15 ~ 46	15 ~ 46

Note: The cooling capacity is measured under the conditions specified by JIS B 8615 based on the reference piping. Indoor 27 degC Dry Bulb / 19 degC Wet Bulb, Outdoor 35 degC Dry Bulb. The sound level is measured in an anechoic chamber in accordance with JIS B 8616

Accessory

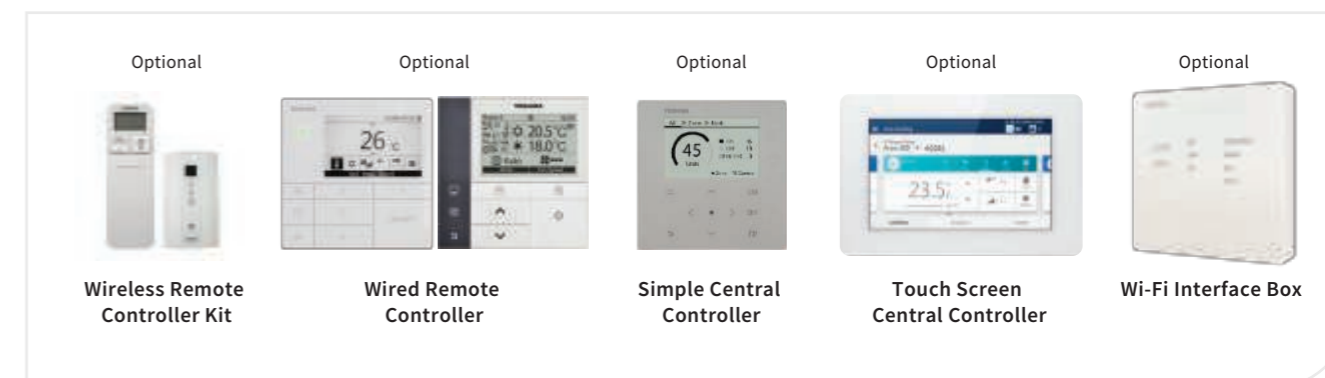



HIGH-WALL TYPE RAV-GE**02KRP

Slim-line design



With its attractive, slim-line design, the unit seamlessly integrates into any room's interior. The filtration system enhances indoor air quality, further contributing to the benefits of this high wall unit.

Optimal air distribution

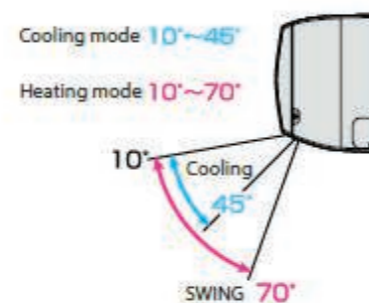

The 70° directional auto-swing louvre mode ensures efficient air distribution throughout the room. Total comfort is achieved through the integration of automatic air volume control as well as automatic cooling.



Technical Specification

Equivalent		HP	1.0	1.5
Model Name	Indoor unit		RAV-GE1002KRP	RAV-GE1302KRP
	Outdoor unit		RAV-GE1002AP-SG	RAV-GE1302AP-SG
				
Power supply (Outdoor unit)			1-phase 50Hz 220-240V	
Cooling capacity (Min-Rated-Max)		kW	0.9-2.5-3.2	0.9-3.5-4.1
Power consumption (Rated)		kW	0.52	0.79
Coefficient of Performance (COP)			4.80	4.43
Running Current		A	2.38	3.57
Recommended Isolator		A	10	10
Indoor unit	Airflow (H/M//L)	m³/h	672 / 540 / 450	702 / 582 / 450
	Sound pressure (H/M/L)	dB(A)	40 / 34 / 29	41 / 36 / 30
	Dimension (HxWxD)	mm	293x798x230	293x798x230
	Weight	kg	10	10
Outdoor unit	Compressor	Type	Single Rotary	
		Motor output	W	600
	Refrigerant charge(R32)	kg	0.47	0.56
	Sound pressure	dB(A)	47	50
	Dimension (HxWxD)	mm	630x800x300	630x800x300
Piping connections	Liquid side	mm	6.4	6.4
	Gas side	mm	9.5	12.7
Maximum total piping length		m	25	25
Maximum height difference		m	10	10
Operation range		°C	15 ~ 46	15 ~ 46

Technical Specification

Equivalent		HP	2.0	3.0	4.0
Model Name	Indoor unit		RAV-GE1802KRP	RAV-GE2502KRP	RAV-GE3602KRP
	Outdoor unit		RAV-GE1802AP-SG	RAV-GE2502AP-SG	RAV-GE3602AP-SG
					
Power supply (Outdoor unit)			1-phase 50Hz 220-240V		
Cooling capacity (Min-Rated-Max)		kW	1.2-5.3-5.6	2.0-6.1-8.5	4.0-8.3-11.2
Power consumption (Rated)		kW	1.14	1.39	2.15
Coefficient of Performance (COP)			4.65	4.38	3.86
Running Current		A	6.20	6.50	9.95
Recommended Isolator		A	16	20	32
Indoor unit	Airflow (H/M//L)	m³/h	960 / 828 / 678	1038 / 912 / 678	1608 / 1350 / 1182
	Sound pressure (H/M/L)	dB(A)	42 / 39 / 35	45 / 41 / 35	49 / 45 / 41
	Dimension (HxWxD)	mm	320x1050x250	320x1050x250	348x1200x280
	Weight	kg	14	14	19
Outdoor unit	Compressor	Type	Twin Rotary		
		Motor output	W	1050	1050
	Refrigerant charge(R32)	kg	0.87	1.00	1.35
	Sound pressure	dB(A)	57	57	59
	Dimension (HxWxD)	mm	890x900x320	890x900x320	890x900x320
Piping connections	Liquid side	mm	6.4	9.5	9.5
	Gas side	mm	12.7	15.9	15.9
Maximum total piping length		m	50	50	50
Maximum height difference		m	30	30	30
Operation range		°C	15 ~ 46	15 ~ 46	15 ~ 46

Note: The cooling capacity is measured under the conditions specified by JIS B 8615 based on the reference piping. Indoor 27 degC Dry Bulb /19 degC Wet Bulb , Outdoor 35 degC Dry Bulb. The sound level is measured in an anechoic chamber in accordance with JIS B 8616

Accessory

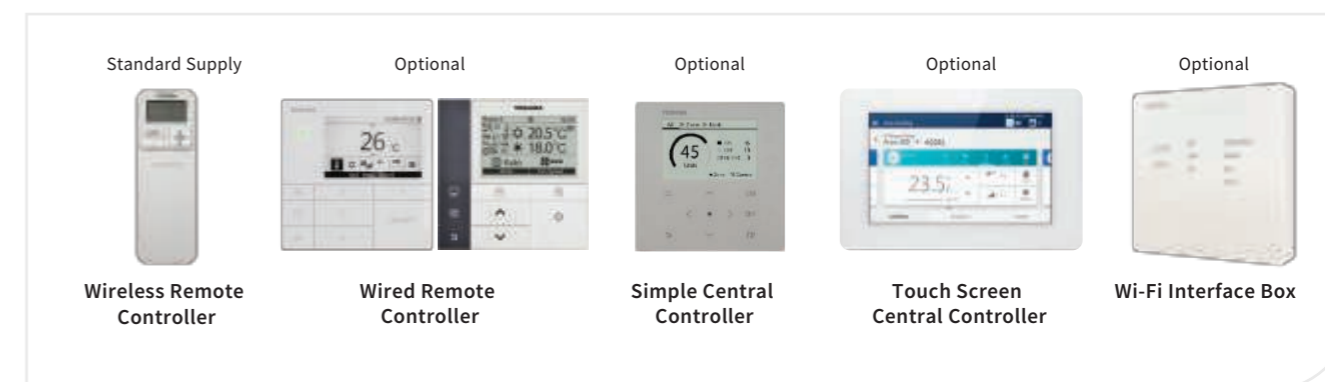

Individual Wired Controller



- Controls 1 indoor unit or a group of up to 8 units
- Large backlit screen with adjustable contrast
- Multi-language menu
- Clock display with date and 12/24-hour time
- Monitors indoor and outdoor temperature
- Scheduled Auto-OFF timer
- 7-day programmable schedule with 8 daily running patterns and holiday timer
- Soft cooling function prevents cold drafts
- Night operation to set the operation time for reduced outdoor unit noise
- Energy optimization via energy-saving operation (adjust temperature limits, schedule slots, set saving ratio) and daily/weekly energy tracking
- Room name setting and display for easy identification and monitoring

Simple Central Controller



- Connects up to 64 indoor units
- Large backlight display with adjustable contrast
- Multi-language menu
- Touch-sensitive keys with adjustable sensitivity
- User-friendly interface with intuitive navigation
- Clock display with date and 12//24-hour time
- Operation control and running status display for individual indoor unit, group (up to 10 groups) or full system
- 7-day operating schedule for all indoor units or specific groups
- Energy saving schedule for weekly schedule and saving ratio setting for all units or specific groups
- Room name setting and display for easy identification and monitoring

Touch Screen Smart Manager



- Connects up to 256 indoor units
- Intuitive 7-inch color touchscreen (800x480 resolution) with adjustable brightness
- Multi-functional interface: Homepage, Real-time status, Visual layout, Batch ON/OFF, Group/Individual settings
- Displays operation status for units/groups: time, capacity, temperature, consumption
- Smart scheduling with weekly schedule and special day programs for individual or group management
- Soft cooling prevents direct airflow and excessive cooling
- Energy-saving mode with savings ratio, temperature limits, detailed consumption tracking for energy optimization
- Night operation to lower outdoor unit operation sound
- Fault alerts via code menu and Email notification

Installation and the use of refrigerants not specified by the Manufacturer

Toshiba refrigeration and air-conditioning units are designed and manufactured on the assumption that the product is used with a specific refrigerant suitable for each unit.

We have recently seen some cases where the type of refrigerant used is different from the one originally installed in the product. Such actions may cause mechanical defects, malfunctions, failures and in some cases result in a serious safety issue. Therefore do not install any refrigerant other than the one specified by the Manufacturer for its respective products.

The type of the refrigerant used for each of our products is shown in the accompanying owners manual, or on the product label attached on the product itself.

The Manufacturer shall not assume any liability for failures, malfunctions or safety in its products if the refrigerant used is different from the one specified.

Safety Precautions ⚠

For operation:

Before use, read through the operating instructions to ensure proper use.

Concerning the purpose for which the air conditioners are to be used

- The air conditioners presented in this catalogue are air conditioning/heating units to be used solely by general consumers.
- Do not use these air conditioners for special applications such as for the storage of food items, animals, plants, precision machines or works of art. Doing so may degrade the quality of the items.
- Do not use these air conditioners for air-conditioning applications in vehicles or ships. Doing so may cause water and/or power leakages.

Precautions for using Air conditioners

Concerning the automatic defrosting unit

When the outdoor air temperature drops, frost may form on the heat exchanger of the outdoor unit. In such cases, the automatic defrosting unit will be activated, and it will take 5 to 8 minutes for the heating operation to be restored.

Concerning the air conditioner's operating conditions and their selection.

(1) Avoid using the air conditioner in the following locations.

- Locations with acidic or alkaline atmospheres (locations at which highly acidic or alkaline air is directly drawn in, such as in hot springs areas from which sulfur gases are given off, or where chemicals, vinegar, exhaust air from burners, etc., are given off) The heat exchangers and other parts may become corroded.
- Locations with atmospheres filled with coolant or other machine oil or steam exhaust (such as at food preparation factories or machine plants). The heat exchangers may corrode; frost may form as a result of heat exchanger malfunction; air conditioner operating performance may be compromised or condensation may form as a result of clogged filters; plastic parts may incur damage; heat insulation materials may become separated, etc.

(2) Before using an air conditioner in any of the following locations, consult with your dealer or a qualified contractor.

- Locations where vapors from edible oils are given off (such as in bakeries or kitchens and restaurants that use edible oils). The air conditioner's operating performance may be compromised or condensation may form as a result of clogged filters, and the plastic parts may incur damage. In line with the prevailing conditions, take counter measures such as tailoring the installation conditions in accordance with the conditions, using air conditioners designed for kitchens or oil guard filters, etc.
- Locations with disinfectant-induced chlorine atmospheres (watertanks, etc.) The metal parts in the heat exchangers, motors, etc., may become corroded.
- Locations with high salinity (coastal areas, etc.) Corrosion may occur so use outdoor units specifically designed to withstand exposure to salt.
- Locations where power is supplied from independent power generators. The power line frequency and/or voltage may fluctuate, possibly causing the air conditioner to malfunction.

generated (from high-frequency welders used for vinyl welding and processing, high-frequency therapeutic devices used for thermotherapy, etc.) The electronic components may be adversely affected, possibly causing the air conditioner to malfunction.

- Locations where electronic equipment is installed. Electrical noise may adversely affect the operation of the electronic equipment.

(3) Concerning use in locations with high ceilings

- In locations with high ceilings, use of circulators for improving the temperature distribution during heating is recommended.

(4) Concerning use in high-humidity environments

- When the ceiling-recessed type of indoor unit is installed in a location, such as those described below, and it is very hot and humid inside the ceiling, condensation may form on the external surfaces of the indoor unit and drip down. In such cases, add external heat-insulating materials.
- Locations such as food preparation sites in which the areas above the ceilings are hot and humid.
- Locations in which outside air is drawn in and routed above the ceiling.
- Above ceilings with a slate roof or tiled roof overhead.

(5) Even when an air conditioner is shut down, it will still consume a small amount of power to protect the unit. If the air conditioner will not be used for a prolonged period, turn OFF the main switch (ground fault circuit breaker). However, before the unit is to be used again, turn ON the main switch (ground fault circuit breaker) for at least 12 hours in order to prevent trouble.